



DAYVIA®

WELLBI

WELLBI



WELLBI : modern and large, it can be placed on a table or hung on the wall. Enjoy a light therapy bath while sharing a moment of conviviality.

WELLBI



- **Well-being** : brings well-being and vitality throughout the day, alleviates depressive states, including winter depression due to lack of light.
- **Design** : its large size makes it a real interior design feature. It is the slimmest on the market.
- **Versatile** : WELLBI has two therapeutic lighting modes enriched with cyan, as well as a warm ambient lighting mode to accompany and enhance your evenings.
- **Smart** : WELLBI has 3 functions with adjustable intensities for optimum comfort and efficiency. With its timer, you can carry out a complete light therapy session.
- **Certified** : proven therapeutic efficacy with CE Medical Device mark.
- **Materials** : steel and recycable aluminium.

Class I medical device: CE marking in accordance with the European regulation on medical devices 2017/745



Warranty : 2 years.

Features

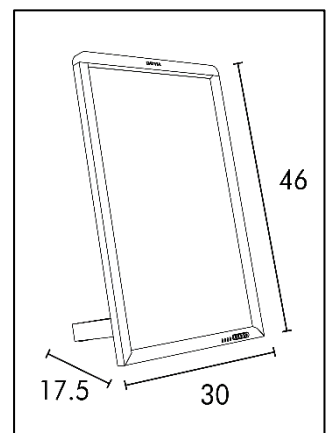

SAP no.	400179590
EAN code	3760189700272
Colour	White
Dimming	3 modes
Melanopic efficiency* ($\mu\text{W}/\text{cm}^2$)	1096 at 30 cm
Lifespan (h)	30 000
Cable length (m)	1.8
Power (W)	25
Weight (kg)	2.2

*Melanopic efficiency corresponds to the ability to excite the melanopsin ganglion cells located in the retina in a given time. It is all the better if the radiation from the device is around 480 nm (cyan colour).

ENVIRONMENT



DAYVIA is committed to sustainable development and is taking concrete steps to reduce its environmental footprint to best meet the changing expectations of its consumers.



We participate in reducing our GHG emissions by 29% between 2021 and 2030 in response to the "Net Zero Carbon Emissions by 2050" challenge. Eco-design, emissions reduction and continuous improvement are at the heart of our concerns.

OUR EXPERTISE

LIGHT THERAPY, HOW IT WORKS ?

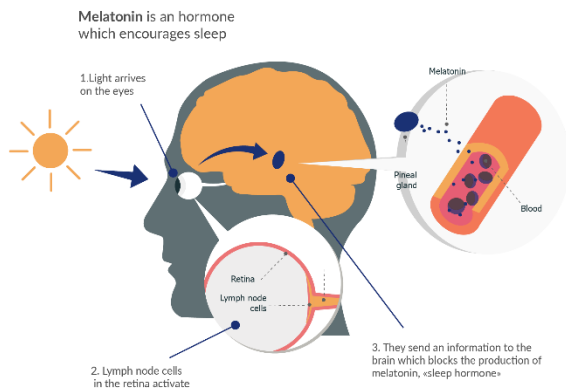

Best melanopic efficiency on the market

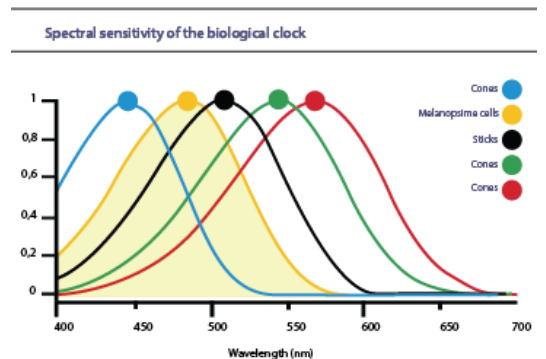

WHAT BENEFITS ?

- **Restore well-being and vitality** thanks to its melatonin-blocking properties.
- Resynchronize the circadian cycle and **improve sleep quality**. It helps you recover more quickly from jetlag and is perfectly suited to night workers.
- Fight against seasonal depression, weariness and gloom.

DAYVIA, AN ENGAGED COMPANY

DAYVIA is the **only French manufacturer** of light therapy products. DAYVIA products are entirely designed and developed in France. DAYVIA assembles its products in Angers in a sheltered workshop, in line with its CSR commitments. DAYVIA works in partnership with ADAPEI, an association that supports and provides practical assistance to people with a range of disabilities and promotes their social and professional integration.

CE MEDICAL DEVICE

DAYVIA meets the requirements of the European Medical Devices Regulation 2017/745 by applying the ISO 13485: 2016 standard, which ensures the conformity of medical devices.

CE Medical Device certified and with a "ZERO" photobiological risk, DAYVIA lamps guarantee reliability, efficiency and safety for the user. The CE Medical Device mark ensures that the manufacturer's products meet all the necessary preconditions for inclusion in the class of medical devices with a real effect on the body.