



UNILUX

---

FLEXIBLE

# FLEXIBLE black

---



The flexible LED e-reader impresses with its elegant lines, its universal and timeless design. Thanks to its 60 cm hose, sheathed in imitation leather, this e-reader is positionable in all directions, allowing its user to direct the luminous flux at his convenience, without difficulty

# SWIVEL FLEXIBLE



- **Convenient to use:** The particularity of this product lies in the fact that its ignition is done by turning the head of the e-reader, an intuitive gesture and a concept that guarantees a long life of this luminaire.
- **Clean design:** it impresses with its elegant lines, universal and timeless **design.** **Protect your eyes:** this lamp is particularly suitable for reading, it does not attack the eyes and helps to create a calm and relaxing atmosphere.
- **Easily adjustable:** Thanks to its 60 cm hose, sheathed in imitation leather, this e-reader is positionable in all directions, allowing its user to orient the luminous flux at his convenience, without difficulty.

Warranty: 2 years

Materials: Steel and aluminum arms, aluminum or copper head, steel or copper plate. Imitation leather sheath.

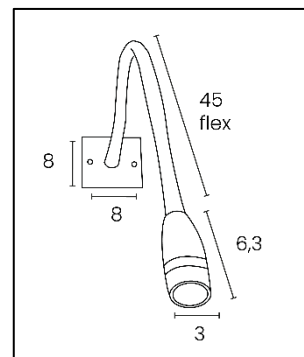
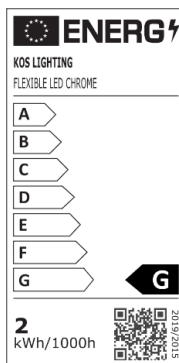
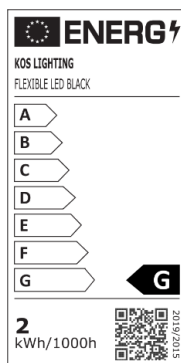

## Characteristics

SAP no.	400053382	400053383
EAN code	3595560010561	3595560010578
Colors	Black	Chromium
Luminous flow	50	50
Lux at 35cm	/	/
Lm/W	25	25
Color T° ( K )	2900	2900
CRI	84	84
Source Lifetime (h)	50 000	50 000
Energy consumption (kWh/1000 h)	2	2
USB Port	No	No
Inductive charger	No	No
Net weight (kg)	590 g	590 g

# USER GUIDE

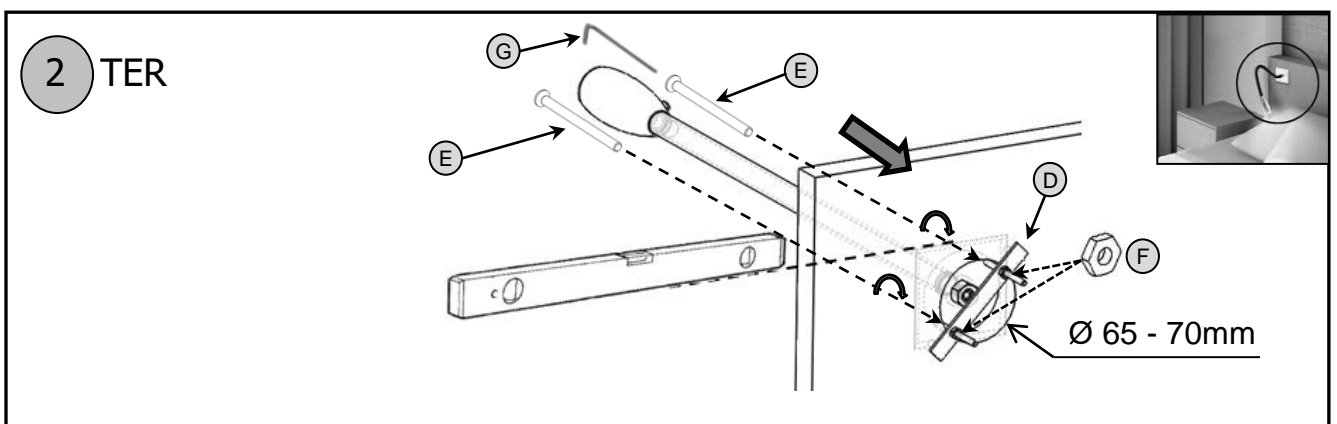
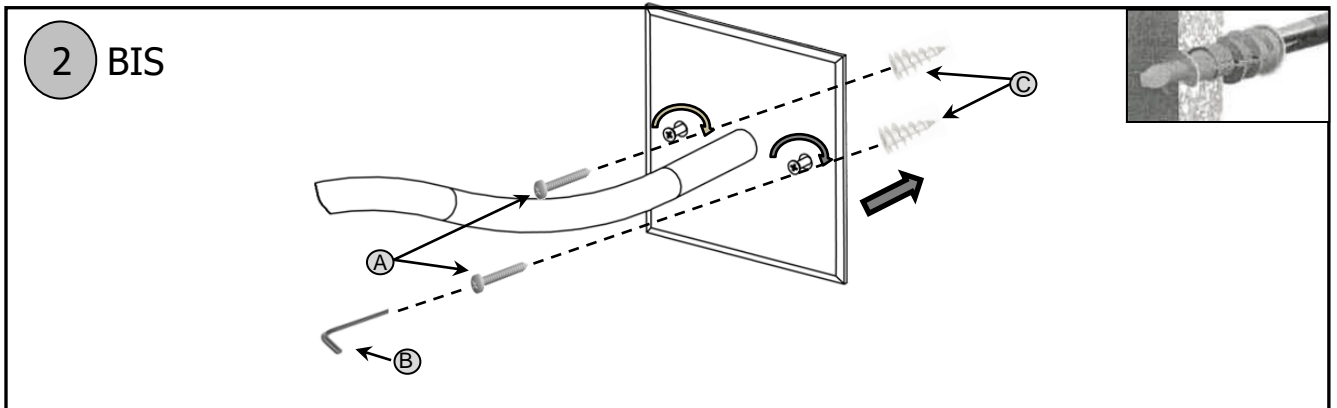
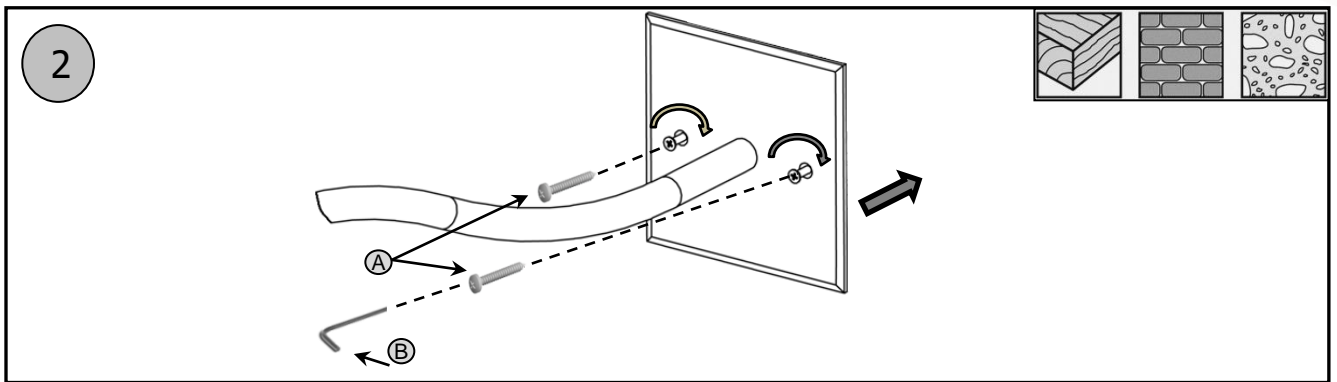
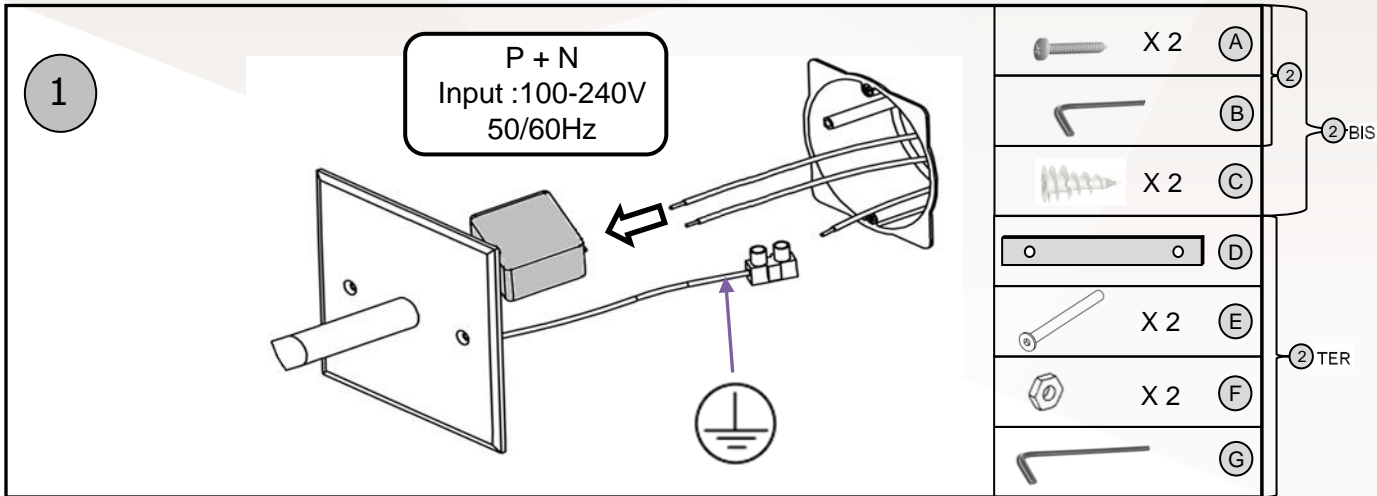

## 30 products available on pCon Planner

You will be able to obtain data on many UNILUX or OFML standard products and integrate them quickly and easily into 3D space layouts via pCon.



## Download on our E-shop

Always available: photos in HD, data sheets, instruction manual, repairability instructions for all our products.



## Do you have any questions?

Our after-sales service is always at your disposal

Tèl: +33 1 81 86 06 03

E-mail: [contact.unilux@hamelinbrands.com](mailto:contact.unilux@hamelinbrands.com)

17 avenue du Parc TECHNOPOLES

91380 Chilly Mazarin – France

Tèl: +33 1 81 86 06 00

[www.my-unilyx.com](http://www.my-unilyx.com)

E-mail: [contact.unilux@hamelinbrands.com](mailto:contact.unilux@hamelinbrands.com)

UNILUX