



UNILUX

REVERSO

Why the range

1-Ecology: a strategic challenge for the HAMELIN group

Ecology is the next big challenge for the HAMELIN group. Following its recent environmental assessment to measure its carbon footprint. HAMELIN has decided to embark on a 10 year plan to reduce its carbon emissions by 15%. To achieve this, OXFORD has developed new eco-friendly ranges based on the recovery and recycling of materials such as cardboard, coffee cups and fishing nets.



Collection OXFORD:
TOUAREG



Collection OXFORD:
REC'UP



Collection OXFORD:
OCEANIS

2- PET

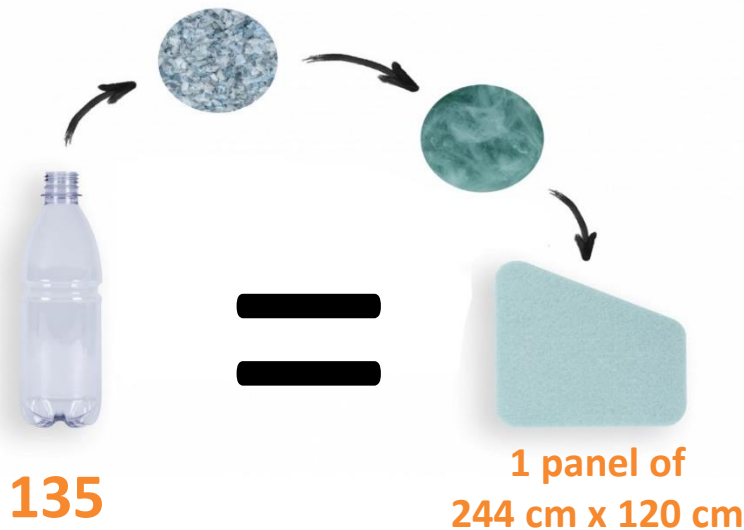

Every year **1.5 million animals** are killed by plastic in the oceans and **89 billion plastic water bottles** are sold every year. One felt panel contains 135 half-litre PET bottles or 102 plastic bottles. In other words, we are constantly extracting 102 to 135 bottles from the ocean per felt panel. Recycling our waste has become essential.

*<https://drisag.be/fr/blog/feutre-recycle-une-nouvelle-vie-pour-les-bouteilles-en-plastique/>

3- The benefits of our PET

1- ECOLOGICAL



The manufacturing process and the nature of the fibres guarantee a very low level of VOC emissions, thus helping to preserve our environment. Our PET is made up of

50% recycled PET and 50% recyclable PET.

2- ACOUSTICS



The fibrous structure of our PET is very effective in trapping sound and reducing noise pollution, especially in open spaces. Its sound absorption coefficient is

0.8 between 500Hz and 1000Hz

3- THERMAL



Our PET absorbs heat and releases it when the temperature drops, thus contributing to a better

thermal inertia and air quality

REVERSO



- **Ergonomic:** REVERSO raises your low screens to a comfortable working height. This limits strain on the neck and shoulder muscles and optimizes reading comfort.
- **Intelligent:** This screen support can be adjusted to two different heights (5 cm or 8 cm) thanks to its ingenious system. You can change the height in seconds by simply flipping the stand.
- **Practical:** Under the REVERSO there is enough space to store your compact keyboard.
- **Eco design:** screen support made entirely of PET (50% recycled%/50% recyclable) with a sound absorption coefficient of 0,8 for standard frequencies between 500 Hertz and 1000 Hertz.
- **Light and sturdy:** the 18 mm thick tabletop can support a weight of 5 kg and its size can accommodate a screen of up to 22 inches.
- **Easy to assemble:** Delivered flat packed in a compact and lightweight packaging, this stand is quick to assemble and thanks to its light weight and click to mount system, it is easy to move around and can even be stored in a carrying case.

Support up to 6 kg
 Dimensions : 50 x 25 x 15 cm
 Mounting time: 1 minute
 Materials : PET

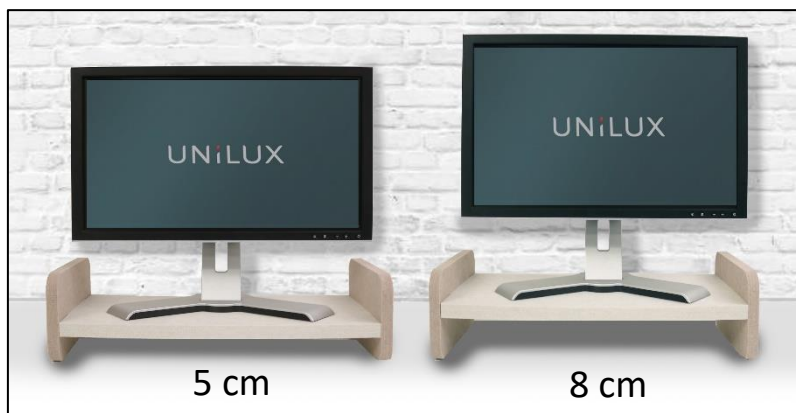

Characteristics

SAP no.	400165144
Colors	Beige/linen
Dimensions	50 x 25 x 15 cm
Warranty	2 years
Net weight	0,65 kg
Height adjustable	Yes
EAN code	3595560034840

OUR CSR COMMITMENTS

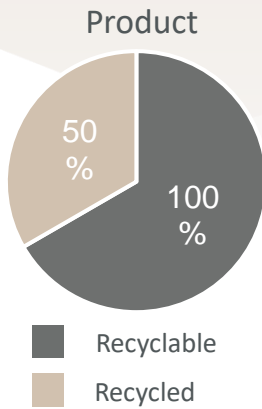

1. All our lighting are **100% repairable** thus limiting planned obsolescence.
2. Reduce our carbon footprint through our **ECO-DESIGN THINKING** approach.
3. Contribute to the preservation of the planet's natural resources by promoting the use of **recycled materials**.
4. Optimize our packaging to control our **transport costs**.
5. Highlight the **talent of our employees** by ensuring social equality.

OUR EXPERTISE

Why use a monitor stand or laptop riser?

These days, more and more people use several screens to accomplish their tasks, so you need to know whether your working position is suitable and ergonomic. Are you sitting up straight? Do you feel that your neck is in its natural, relaxed position? When you look at your screen, do you keep your gaze straight, without looking up or down? If the answer to these simple questions is no, it's high time you bought yourself a laptop stand with a screen riser or even a screen support arm. These will enable you to align your eyes correctly with the top of your screen and prevent RSI by reducing neck strain.

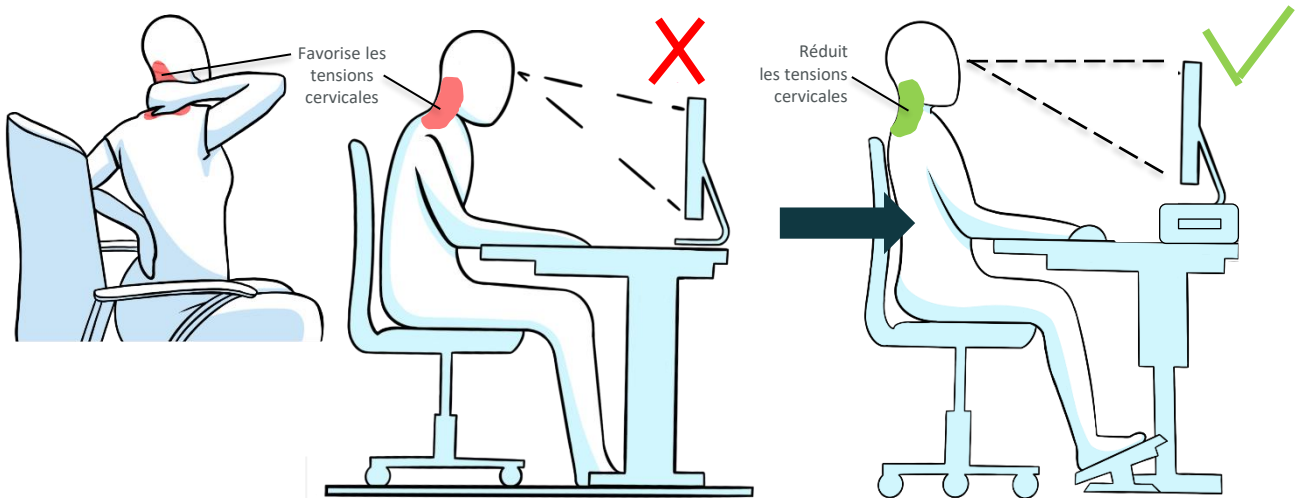

OUR CERTIFICATIONS

Unilux is committed to an eco-responsible approach and ensures that its products respect this commitment. Indeed, we are very concerned about current environmental issues and we aspire to respond as best as possible to the concerns of our consumers on this subject. Sustainable development is at the heart of our strategy and we act for the environment. You will find below the different certifications that Unilux has and that prove its environmental commitment.



GUIDE D'UTILISATION

i



x1



www.my-unilux.com

+

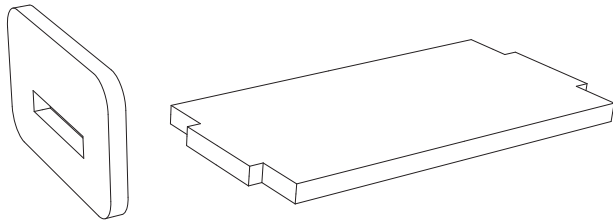

A x2 **B** x1

1

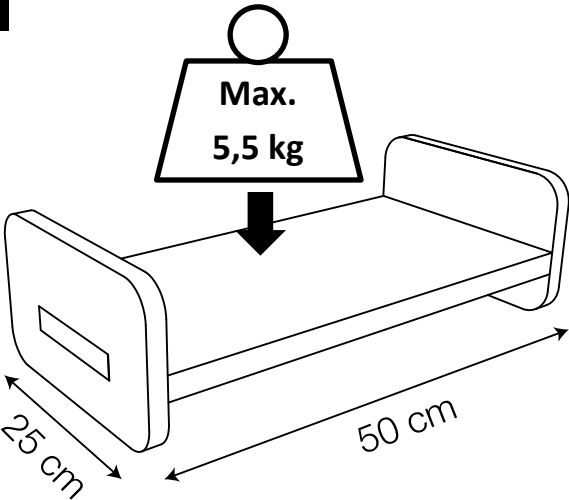

Max.
5,5 kg

15 cm

25 cm

50 cm

2

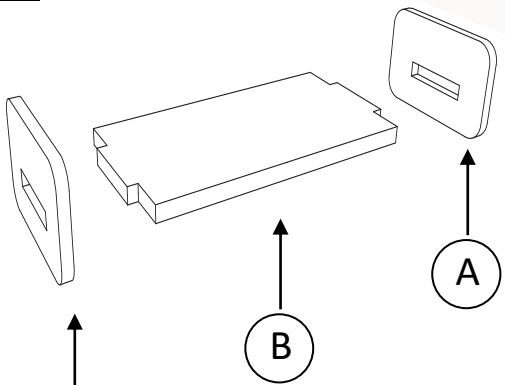

A **B** **A**

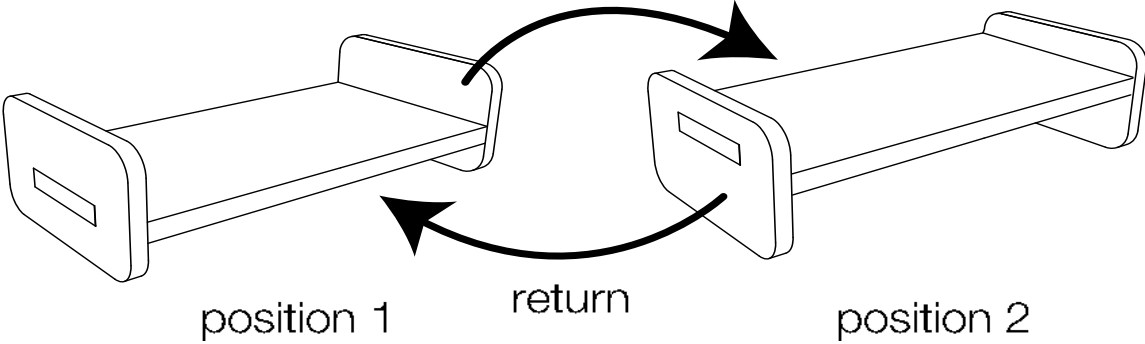

position 1 return position 2

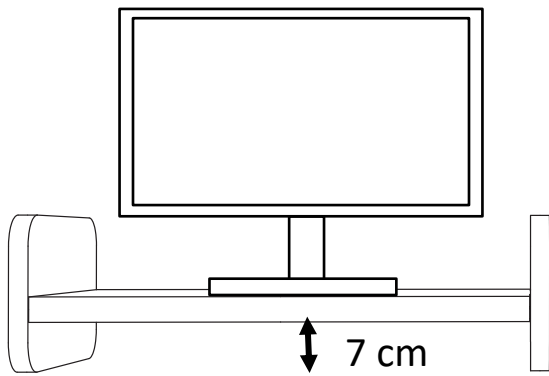

7 cm

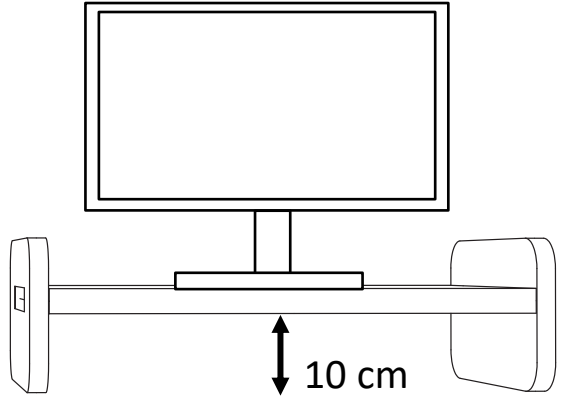

10 cm

30 products available on pCon Planner

You will be able to obtain data on many UNILUX or OFML standard products and integrate them quickly and easily into 3D space layouts via pCon.



Download on our E-shop

Always available: photos in HD, data sheets, instruction manual, repairability instructions for all our products.



Do you have any questions?

Our after-sales service is always at your disposal

Tèl: +33 1 81 86 06 03

E-mail: contact.unilux@hamelinbrands.com

17 avenue du Parc TECHNOPOLES

91380 Chilly Mazarin – France

Tèl: +33 1 81 86 06 00

www.my-unilyx.com

E-mail: contact.unilux@hamelinbrands.com

UNILUX