



UNILUX

NEXUS

Why the range

1-Ecology: a strategic challenge for the HAMELIN group

Ecology is the next big challenge for the HAMELIN group. Following its recent environmental assessment to measure its carbon footprint. HAMELIN has decided to embark on a 10 year plan to reduce its carbon emissions by 15%. To achieve this, OXFORD has developed new eco-friendly ranges based on the recovery and recycling of materials such as cardboard, coffee cups and fishing nets.



Collection OXFORD:
TOUAREG



Collection OXFORD:
REC'UP



Collection OXFORD:
OCEANIS

2- PET

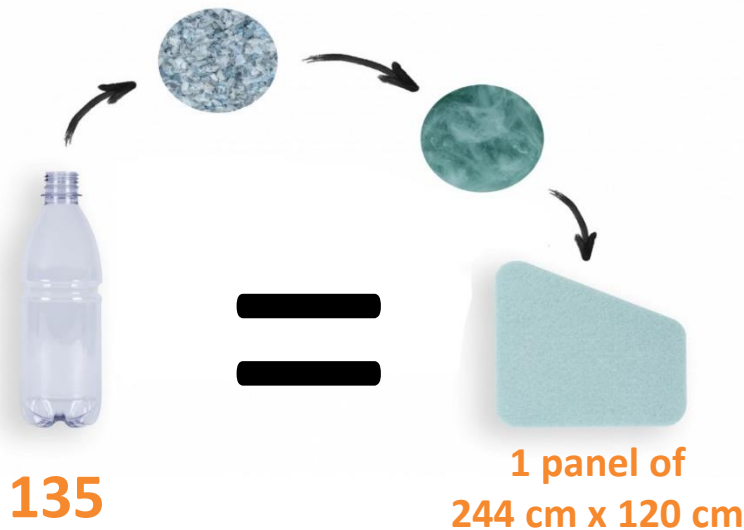

Every year **1.5 million animals** are killed by plastic in the oceans and **89 billion plastic water bottles** are sold every year. One felt panel contains 135 half-litre PET bottles or 102 plastic bottles. In other words, we are constantly extracting 102 to 135 bottles from the ocean per felt panel. Recycling our waste has become essential.

*<https://drisag.be/fr/blog/feutre-recycle-une-nouvelle-vie-pour-les-bouteilles-en-plastique/>

3- The benefits of our PET

1- ECOLOGICAL



The manufacturing process and the nature of the fibres guarantee a very low level of VOC emissions, thus helping to preserve our environment. Our PET is made up of

50% recycled PET and 50% recyclable PET.

2- ACOUSTICS



The fibrous structure of our PET is very effective in trapping sound and reducing noise pollution, especially in open spaces. Its sound absorption coefficient is

0.8 between 500Hz and 1000Hz

3- THERMAL



Our PET absorbs heat and releases it when the temperature drops, thus contributing to a better

thermal inertia and air quality

NEXUS



NEXUS is the first floor lamp that combines both lighting and sound absorption thanks to its recycled PET acoustic panel. Its separate direct and indirect lighting will bring you excellent lighting quality.



- **Ease of use:** Thanks to its touch control, it is easy to vary the light and choose to illuminate up or down or both at the same time. Thanks to its separate lighting function, the NEXUS has quality and powerful lighting without effect, thus providing excellent visual comfort (low luminance and very good UGR below 19).
- **Design and innovation:** first luminaire that combines both lighting function and sound absorption thanks to its PET acoustic panel (50% recycled/50% recyclable) with a sound absorption coefficient of 0.8 for standard frequencies between 500 Hertz and 1000 Hertz. It is held on both parts of the luminaire by a clip.
- **Intelligent:** automatic adjustment of the intensity according to the ambient light and energy savings thanks to its cell with presence detection.
- **Stability:** the base cut from an 8 mm thick sheet metal allows the floor lamp to be positioned as close as possible to a desk or table leg thanks to its U-shape.
- **Collaborative:** it allows to illuminate 2 stations with excellent uniformity.

Warranty: 2 years
 Height: 198 cm
 Head with panel: 40 x 70 cm
 Touch dimmer on mast, height: 110 cm
 Packaging in a single carton
 Structure with Epoxy paint / recyclable aluminum
 / PET thickness 9 mm



Professional replaceable light source (LED only)

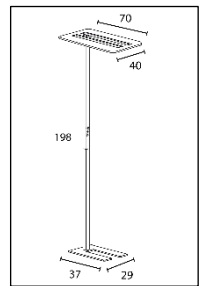

Characteristics

Lux measurement downwards 110 cm from the light source:

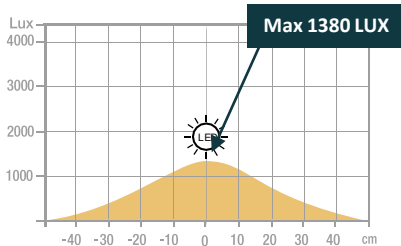

Lux measurement upwards 55 cm from the light source:

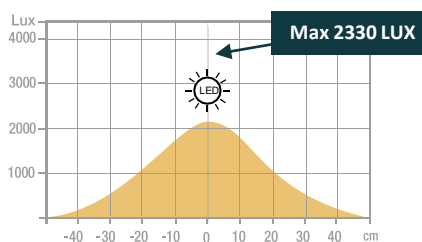

Measurement in nanometers of the light spectrum

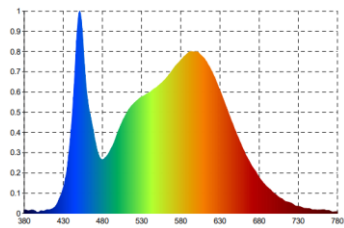

| | |
|--------------------------------|---------------|
| SAP. code | 400165148 |
| EAN code | 3595560034888 |
| Colors | White/Linen |
| Luminous flow (Lm) | 5935 |
| Lux at 110 cm direct (Lx) | 1380 |
| Lux at 55 cm in direct (Lx) | 2330 |
| Luminous Efficiency (Lm/W) | 110 |
| Color T*(K) | 4000 |
| CRI | 84 |
| Source's lifetime (h) | 40 000 |
| Energy Consumption (kWh/1000h) | 54 |
| Net weight (kg) | 12,5 |

OUR CSR COMMITMENTS

Product

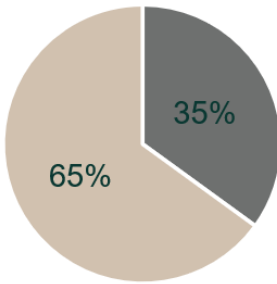

Packaging

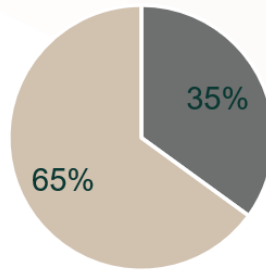

Energy class

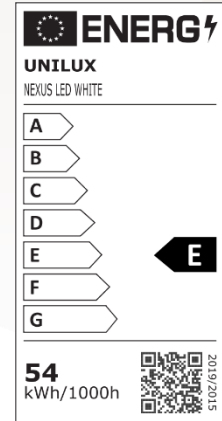

OUR EXPERTISE

1- Floor lamp with direct and indirect lighting: the ideal and optimal lighting on your desk

The right lighting activates and motivates, it stimulates concentration and performance. Poor work lighting quickly causes health problems like muscle aches, headaches, and eye strain as the body tries to compensate for poor visual conditions.

Improve the result by adapting the lighting to individual needs on the workstation. The more difficult the visual task, the higher the illumination must be. 34% of offices reach the level of illumination of 500 Lux prescribed by occupational medicine.

Installing a lamp with direct and indirect lighting on your workstation allows you to adapt the lighting according to the activity (reading, writing, data processing, etc.), limit glare and reduce the areas contrasts that cause eye strain.

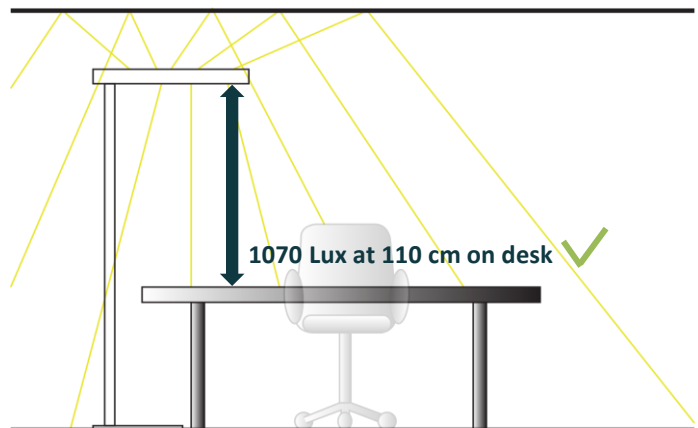

Lighting according to DIN EN 12464-1 * for the office

- **300 Lux:** deposit, copy, circulation areas
- **500 Lux:** writing, reading, data processing
- **500 Lux:** at the reception and at the counter
- **750 Lux:** technical drawing

OUR CERTIFICATIONS

Unilux is committed to an eco-responsible approach and ensures that its products respect this commitment. Indeed, we are very concerned about current environmental issues and we aspire to respond as best as possible to the concerns of our consumers on this subject. Sustainable development is at the heart of our strategy and we act for the environment. You will find below the different certifications that Unilux has and that prove its environmental commitment.



UNILUX

* DIN EN 12464-1 (DIN 5035-1): European standard which determines the lighting requirements for workstations in closed places, these satisfying the needs of comfort and visual performance. DIN EN 12464-1 replaced DIN 5035-1

30 products available on pCon Planner

You will be able to obtain data on many UNILUX or OFML standard products and integrate them quickly and easily into 3D space layouts via pCon.



Download on our E-shop

Always available: photos in HD, data sheets, instruction manual, repairability instructions for all our products.



Do you have any questions?

Our after-sales service is always at your disposal

Tèl: +33 1 81 86 06 03

E-mail: contact.unilux@hamelinbrands.com

17 avenue du Parc TECHNOPOLES

91380 Chilly Mazarin – France

Tèl: +33 1 81 86 06 00

www.my-unilyx.com

E-mail: contact.unilux@hamelinbrands.com

UNILUX