



UNILUX

LEDDY

LEDDY black



LEDDY white



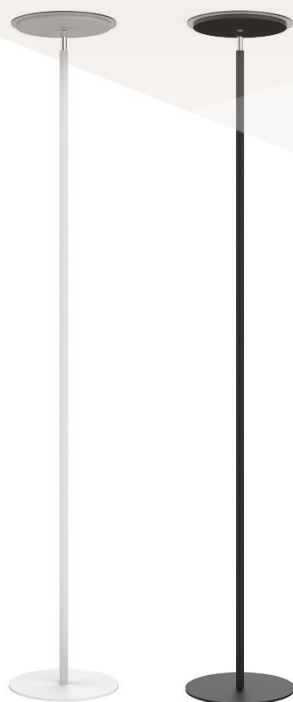

- **Easy to use:** its 3-intensity touch dimmer located on the mast allows you to find the most comfortable lighting for reading, writing and working.
- **Clean and modern design:** the finesse of its barrel, its sober lines and its frosted glass diffuser will bring a light and modern look to your office.
- **Hygiene:** Equipped with a glass, the basin is protected from insects and is easy to clean.
- **Longevity:** the lifespan of its LEDs is estimated at more than 40,000 hours.
- **Uniform light diffusion:** indirect lighting without glare, you will benefit from quality accent lighting.

Warranty: 2 years

Height: 180 cm

Head: Ø 25 cm

Base of the floor lamp in stable metal: 2.5 kg

Materials: Fully made of top quality steel with Epoxy paint finish with frosted glass



Professional replaceable light source (LED only)

Characteristics

Lux measurement upwards 55 cm from the light source:

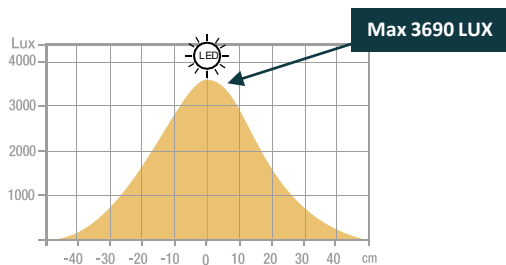

Measurement in nanometers of the light spectrum

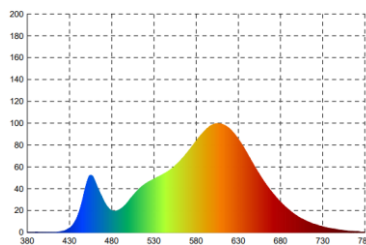

SAP. code	400165031	400124563
EAN code	3595560034406	3595560029556
Colors	White	Black
Luminous flow (Lm)	4764	4764
Lux at 55 cm (indirect)	3690	3690
Luminous Efficiency (Lm/W)	149	149
Color T°(K)	3000	3000
CRI	84	84
Source's lifetime (h)	40 000	40 000
Energy Consumption (kWh/1000h)	32	32
Net weight (kg)	4,33	4,33

OUR CSR COMMITMENTS

1. All our lighting are **100% repairable** thus limiting planned obsolescence.
2. Reduce our carbon footprint through our **ECO-DESIGN THINKING** approach.
3. Contribute to the preservation of the planet's natural resources by promoting the use of **recycled materials**.
4. Optimize our packaging to control our **transport costs**.
5. Highlight the **talent of our employees** by ensuring social equality.

Energy class

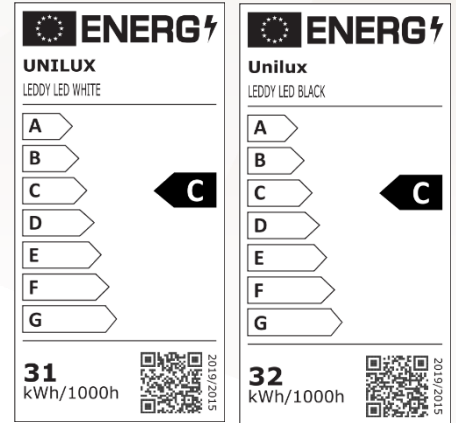

OUR EXPERTISE

1- Floor lamp with indirect lighting: An essential complementary light!

Because they're so easy to install and so decorative, indirect-lighting floor lamps are a firm favourite with the French! This floor lamp is ideal for illuminating a specific area of a room, or for adding a small, original decorative touch that will change the whole atmosphere of the room.

Thanks to its upward-directed light, which will reverberate off the ceiling, this floor lamp generally acts as a secondary or ambient light, providing you with high quality, high-performance lighting. It blends in perfectly with any room in your business:

- individual office
- open space
- meeting rooms
- high-traffic areas such as reception halls

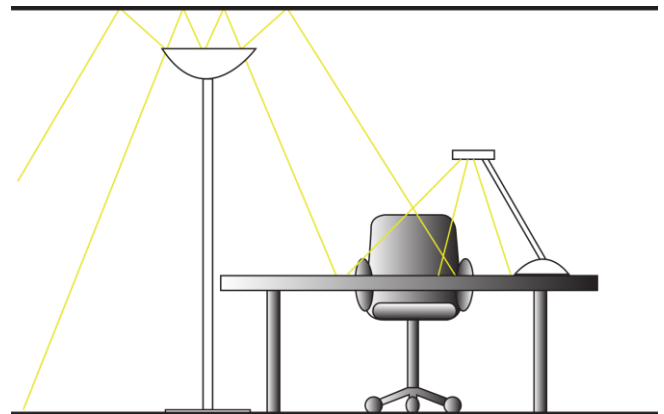



OUR CERTIFICATIONS

Unilux is committed to an eco-responsible approach and ensures that its products respect this commitment. Indeed, we are very concerned about current environmental issues and we aspire to respond as best as possible to the concerns of our consumers on this subject. Sustainable development is at the heart of our strategy and we act for the environment. You will find below the different certifications that Unilux has and that prove its environmental commitment.

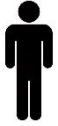

* DIN EN 12464-1 (DIN 5035-1): European standard which determines the lighting requirements for workstations in closed places, these satisfying the needs of comfort and visual performance. DIN EN 12464-1 replaced DIN 5035-1

USER GUIDE

i  x1  4 mins  x1

 www.my-unilux.com

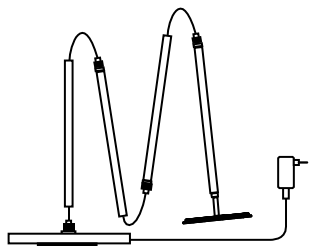
  **A** x1

1

Attach the arm to the base by screwing it

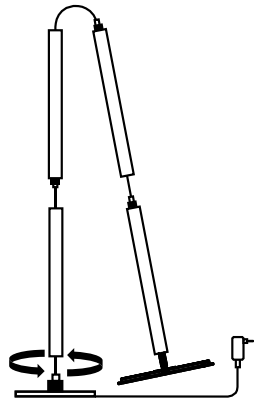

2

Fix the different parts of the arm by screwing them together

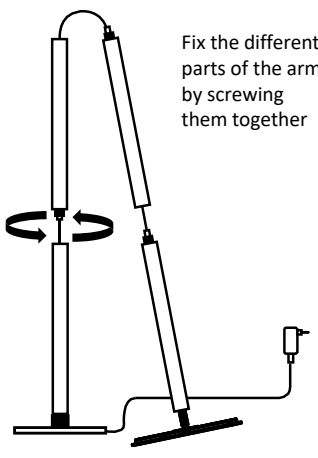

3

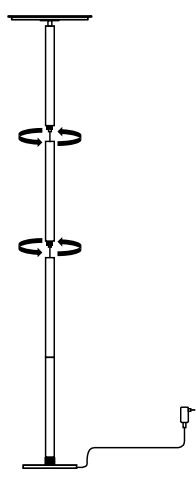

4

✓

⚠

Press the cable correctly

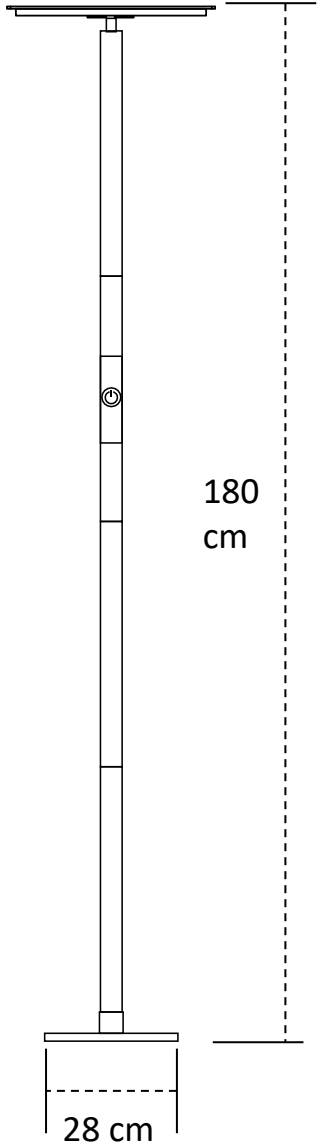
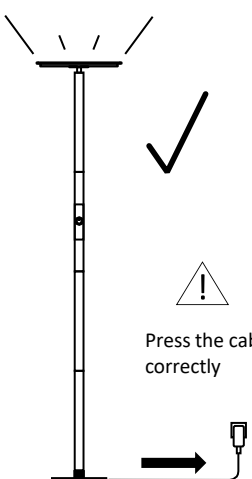

180 cm

28 cm

 The dimmer increases brightness with a single click.

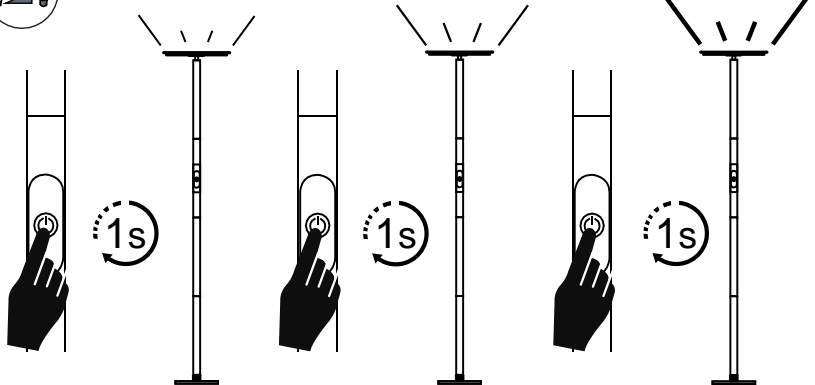

30 products available on pCon Planner

You will be able to obtain data on many UNILUX or OFML standard products and integrate them quickly and easily into 3D space layouts via pCon.



Download on our E-shop

Always available: photos in HD, data sheets, instruction manual, repairability instructions for all our products.



Do you have any questions?

Our after-sales service is always at your disposal

Tèl: +33 1 81 86 06 03

E-mail: contact.unilux@hamelinbrands.com

17 avenue du Parc TECHNOPOLES

91380 Chilly Mazarin – France

Tèl: +33 1 81 86 06 00

www.my-unilyx.com

E-mail: contact.unilux@hamelinbrands.com

UNILUX