

i

x1 10 min

???

www.my-unilux.com

+

No.	Image	Spec	Qty	
A		M6x16mm	8	
B		S14.2x20mm	26	
C		M8x35mm	8	
D		Square spacer	6	
E		Wrench 4x4mm	Wrench 5x5mm	1

No.	Part	Qty	No.	Part	Qty
1	Pedestal	2	2	Lifting Column	2
3	Supporting beam	1	4	Supporting plate	2
5	Cable management	2	6	Control box	1
7	Handswitch	1	8	Power cable	1

Attention: The drawings below are only for reference which might be slightly different from the actual object, please in kind prevail. Any tools missing or installation problems, please contact the customer service firstly.

few minutes

Column qty	3	Input Voltage	100-240V
Max Loading capacity	125KG	Max Speed	38mm/ s
Height range	600-1230mm	Temperature	0-40°C
Length range	1100-1800mm	Certification	CE FCC CUL
Frequency	continuous operation for 2 mins at most after pause for 18 mins		

Adjust the desk upwards ↑

Adjust the desk downwards ↓

LED display

Memory button for height memory function

Alarm button for reminding of keeping same position for long time

Position 3, third height position saved by user

Position 2, second height position saved by user

Position 1, first height position saved by user

1

Install Pedestal (1) & Lifting Column (2) together, use 4*4 wrench(E) to tighten the screws(A).

2

Install cable management(5), tighten/untighten the screw by hand directly.

Adjust the length of the supporting beam according to the actual table Size.

Use 4*4 wrench (E) to untighten the screw on the back of supporting beam in case you need to adjust the length.

After adjusting, please tighten the screw

3

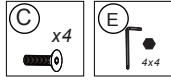

Install the supporting beam (3) use 5*5 wrench (E) to tighten the screws (C)

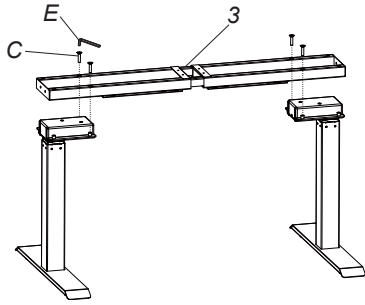

4

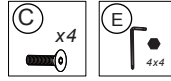

Install supporting plate (4), use 5*5 wrench (E) to tighten the screws (C).

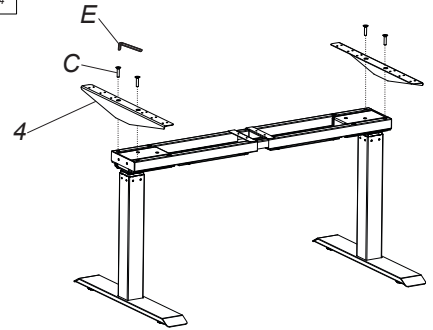

5

Connect all the cables onto the control box (6)

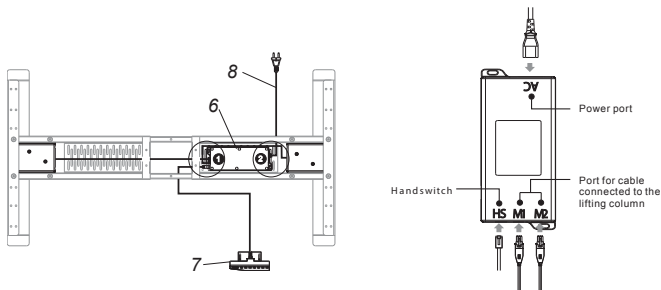

6

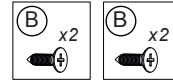

put the table onto the two supporting plates

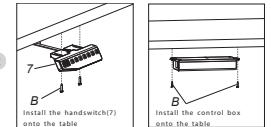
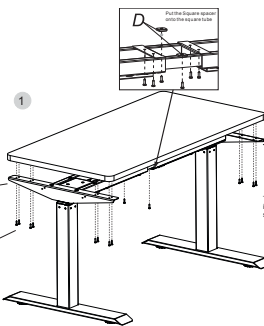

Control box could be installed onto the cable management Attention plate or table
 Pls choose a proper position according to actual circumstance
 Attention

HOW TO USE IT

Instruction

- Press the UP button or DOWN button to lift or lower the height of desks surface. The LED displays show the real time value. The range of the height value: 60.0cm - 123cm.
- Saving Height Position
 - a. Press the UP button or DOWN button to lift or lower the height of desks surface. For instance, you adjust the height to 80cm.
 - b. Press "M" + "S" + AVE button and the LED displays shows "S2", then press "1" to save the height position to 80cm. The LED displays shows "S2".
 - c. Repeat the steps above to save the 2nd height position to 100cm. The LED displays shows "S2". Save the 3rd height position to 120cm. The LED displays shows "S3".
 - d. Press "1", "2", "3", to automatically each the heights saved before.
- Long-Time Sitting Reminder
 - a. Press REMINDER button "A" to activate the function. The LED displays shows "06".
 - b. Two seconds later, press the "▲" or "▼" button to adjust the reminder time only when the display screen flashes. Then press any button to save the time setup, or wait 5 seconds and system will save the time setup automatically. During the countdown, a no-operation will lead to a repeat starting of the timer. When the countdown finishes, the buzzer will be active with a 10-second "DiDi...DiDi...DiDi..." tone.
 - c. Within the 10-second reminder buzz, press any button to reactivate the time countdown that is set up in (b) step. If no operation during the 10-second reminder buzz, there will be a nother reminder buzzer after 5 minutes. No operation during the second buzzer will turn off the Long-Time Sitting Reminder.
 - d. Press and hold the "A" button for three seconds to turn off the Long-Time Sitting Reminder. The LED displays shows "04".
- Troubleshooting
 - a. Reset: When the LEDs shows "S2", press "1" button until the desk reaches its lowest height and rebounds to top, it means the reset has been finished.
 - b. When it doesn't work and the LEDs shows "E01" or "E02", please entry 18 mins later.
 - c. If the "1" button doesn't work, please check the cable connection and then cut off the power for at least 10 seconds. Reconnect the power and press "1" button to start the reset process when it shows the "S2".
 - d. If all these above processes are inefficient, please contact our customer service.

COMMON FAULT TREATMENT

Fault phenomenon	Method
No response while long pressing down arrow after connected with a power supply	1. Check if all the cables be connected well 2. Contact your supplier or dealer
No response while pressing up arrow/down arrow after connected with a power supply	1. Check if all the cables be connected well 2. Contact your supplier or dealer
Rising in a low speed	1. Check if overloaded, max loading: 125kg; 2. Contact your supplier or dealer
The motor not move as instructed	1. Contact your supplier or dealer
Go down but not go up	1. Reposition 2. Contact your supplier or dealer
Downward sliding	1. Check if overloaded, max loading: 125kg; 2. Contact your supplier or dealer
Frequently Reposition	1. Check if overloaded, max loading: 125kg; 2. Contact your supplier or dealer
Overwork (Duty cycle: Max 2min on/18min OFF)	1. Restart after suspend for 18mins while connecting with power. 2. Contact your supplier or dealer;
Not enough up&down height	1. Press "M" and "3" together for 3 seconds or more, after hearing continuous beeping for twice, it will restore factory settings. 2. Contact your supplier or dealer

The following tips will help you detected and eliminate the common fault and error. If the fault you met is not listed below, please contact with your supplier. Only the manufacturer and professionals are capable of investigating and correcting those fault and error.

1. Power supply: AC100V-240V, 50/60HZ
2. Service Environment: 0-40°C
3. Unplug the power plug before cleaning, wipe the dust on surface with slight wet dishcloth when cleaning, be careful not to let the drops into the internal parts, not loose the connector.
4. The electric box contains electronic components, metals, plastics, wires etc., so dispose of it in accordance with each country's environmental legislation, not the general household waste.
5. Check carefully to ensure correct and complete assembly before using.
6. Be familiar with all functions and program settings of the product before first use.
7. Children are forbidden to play on the product because of unforeseen action when playing, so any dangerous consequences caused by this improper action will not be on effect on the use of the equipment.
8. Slight noise caused by the V-ribbed belt or brake system due to structure will not have any effect on the use of the equipment.
9. Corrosive or abrasive materials are forbidden to clean the equipment. Must ensure that the cleaner used will not pollute the environment.
10. This appliance can be used by children aged from 8 years and above and persons with reduced physical, sensory or mental capabilities or lack of experience and knowledge if they have been given supervision or instruction concerning use of the appliance in a safe way and understand the hazards involved. Children shall not play with the appliance.
11. Cleaning and user maintenance shall not be made by children without supervision.
12. If the supply cord is damaged, it must be replaced by the manufacturer, its service agent or a similarly qualified person in order to avoid a hazard.
13. Please make sure there is no hazard sources in your operating environment, e.g., do not litter the tools around. Always be careful to treat the packaging materials in order to avoid any possible danger, e.g., plastic bag may lead to choking hazard to children.
14. Keep the original package of the equipment if necessary in case of the future use in transportation.

WASTE DISPOSAL

This marking indicates that this product should not be disposed with other household wastes. To prevent possible harm to the environment or human health from uncontrolled waste disposal, recycle it responsibly to promote the sustainable reuse of material resources. To return your used device, please use the return and collection systems or contact the retailer where the product was purchased. They can take this product for environmental safe recycling.



Attention