

i

x1 1 min

www.my-unilux.com

FR : Source lumineuse remplaçable (LED uniquement) par un professionnel
EN : Replaceable (LED only) light source by a professional

DE : Auswechselbare (nur LED) Lichtquelle durch einen Fachmann
ES : Fuente de luz reemplazable (sólo LED) por un profesional
IT : Sorgente luminosa sostituibile (solo LED) da un professionista
DK : Udskiftelig (kun LED) lyskilde af en professionel
NL : Verwisselbare (alleen LED) lichtbron door een vakman
SE : Utbytbar ljuskälla (endast LED) av en professionell
FI : Vaihdeettava (vain LED) valonlähde ammattilaisen toimesta.
NO : Utskiftbar (kun LED) lyskilde av en profesjonell
PL : Wymienialne (tylko LED) źródło światła przez profesjonalistę
PT : Fonte de luz substituível (apenas LED) por um profissional

A x1

B x1

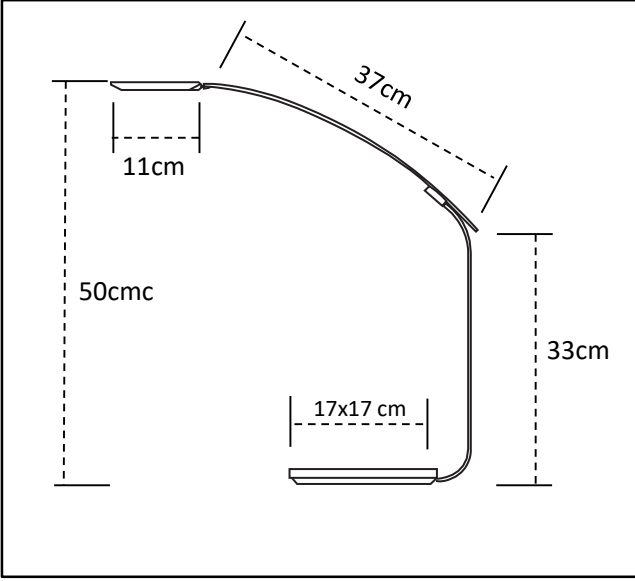

1 Attach the arm to the base and the head to the arm.

2 Your lamp is ready to be used.

⚠ The light source contained in this fixture may only be replaced by the manufacturer or its service agent or a similarly qualified person

< 1sec → ON/OFF

> 1sec →

INDUCTION CHARGER

If your phone has a built-in wireless receiver, it will be charged directly when you place it on the charging area of the lamp base

If your phone does not have a built-in wireless receiver, purchase one, then connect the receiver to your phone and place it on the charging area of the lamp base, your phone will be charged

BLUETOOTH CONNECTION

Compatibility of Bluetooth connection with Apple devices:
 Timelight is compatible with Iphones, from Iphone 4S and following models ,and Ipads, from Ipad wifi 3rd generation and following models.
 All other previous Apple devices are not compatible

CONNECTION TO THE APPLICATION « MY UNILUX »



1 Download Unilux application



2 Launch MyUnilux application



3 Connect your light to your smartphone



4 Personalize your Circadian circle : Define the three time steps of your day : The light you need in the morning , in the middle of the day and at the end of the day.



5 Choose automatic or manual mode

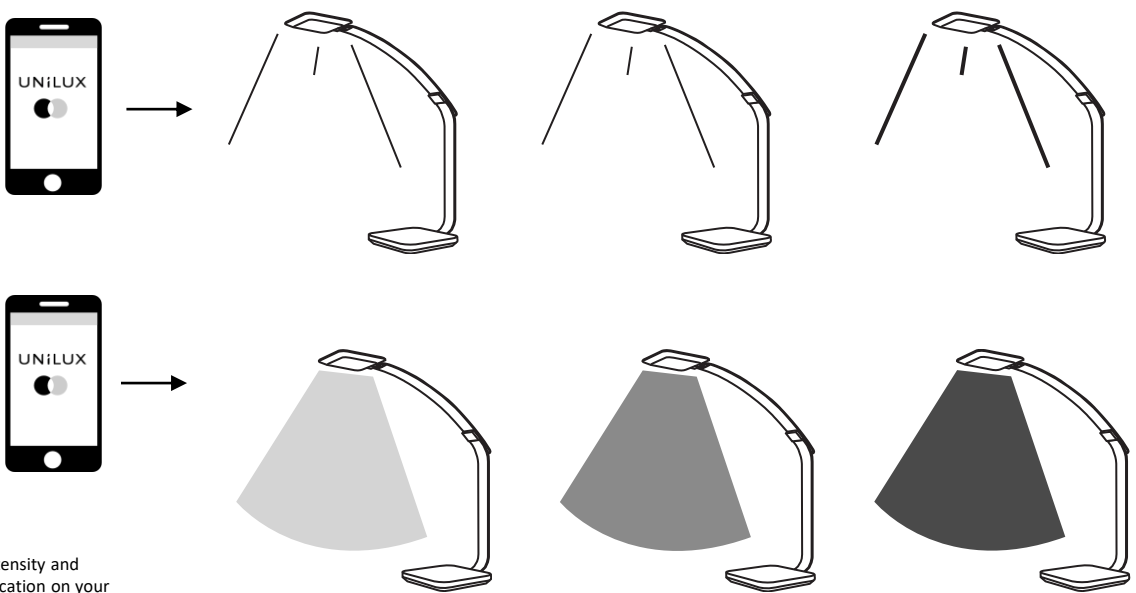

Increase or decrease Brightness

Different color temperatures

You can modify and adapt the intensity and color of the light via Unilux application on your phone only.

Why respect your circadian cycle is important?

Improve your well-being by respecting your circadian cycle!

Natural light is as important to health as balanced food, regular exercise and sleep. This natural light helps keep you healthy and acts on our circadian rhythm for millions of years. But what is the circadian rhythm?

It is the biological rhythm that regulates our heart rate and body temperature, acting in particular on our sleep, our mood, our memory and even our cognitive abilities. But what is it influenced by? Simply by the daily contribution of the natural light. This plays a fundamental role on our biological clock and on the secretion of hormones such as melatonin, the rate of which increases the sensation of sleep. A white light will reduce it while it will increase, at night, with a more yellow light.

And yet, we spend nearly 90% of our time indoors and are subjected to constant artificial lighting every day!

A cold white light, enriched in blue, wakes you up in the morning and boosts you after your lunch break, while a warm white light in the evening is the signal of the relaxation. This biologically effective light will stabilize your circadian rhythm in the long run. This stabilization leads to more well-being and therefore optimized efficiency and an increase in your productivity throughout the day.

It is proven by taking care of your biological clock to limit your risks of insomnia, irritability and concentration disorders.

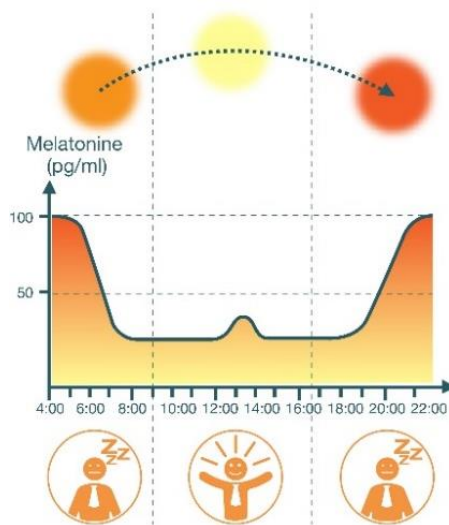

EN : If the outer soft cable or the wire is damaged, it must be replaced exclusively by the manufacturer, his service department or any person of similar qualification, in order to avoid any risk. LED light. Do not stare into beam. **This product contains a light source of energy efficiency class « F »**

DE : Sollte das äußere Kabel oder die innere Leitung dieser Leuchte beschädigt sein, darf es ausschließlich nur vom Hersteller, seinen Wartungstechnikern oder von qualifiziertem Personal ausgetauscht werden, um jegliche Risiken zu vermeiden. LED-Leuchte. Nicht in den Lichtstrahl schauen. **Dieses Produkt enthält eine Lichtquelle der Energieeffizienzklasse « F »**

NL : Indien de buitenkant van de kabel is beschadigd, dient deze te worden vervangen door de fabrikant, zijn servicedienst of een persoon van vergelijkbare kwalificatie, om elk risico te vermijden. LED lamp. Niet langdurig in de lamp kijken. **Dit product bevat een lichtbron van energie-efficiëntieklasse « F »**

FR : Si le câble extérieur souple ou le cordon de ce luminaire est endommagé, il doit être remplacé exclusivement par le fabricant, son service de maintenance ou toute personne de qualification équivalente, ceci afin d'éviter tout risque. Lumière LED. Ne pas fixer directement le rayon lumineux. **Ce produit contient une source lumineuse de classe d'efficacité énergétique « F »**

ES : Si el cable exterior flexible o el cordón de este alumbrado se dañan, debe ser sustituido exclusivamente por el fabricante o su servicio de mantenimiento o toda persona de calificación equivalente, esto con el fin de evitar todo riesgo. Luz LED. No mirar fijamente al haz. **Este producto contiene una fuente luminosa de la clase de eficiencia energética « F »**

PT : Se o cabo exterior ou o fio estiverem danificados, os mesmos devem ser substituído exclusivamente pelo fabricante, pelo seu serviço técnico ou uma pessoa devidamente qualificada para o efeito, a fim de se evitar qualquer risco. Luz LED. Não olhe directamente para a mesma. **Este produto contém uma fonte de luz da classe de eficiência energética « F »**

IT : Se il cavo elettrico esterno o il cablaggio di questa lampada è danneggiato deve essere sostituito esclusivamente dal produttore, dal proprio servizio di manutenzione o da persone con qualificazione adeguata, questo per evitare qualsiasi rischio. Luce prodotta da LED. Non fissare direttamente il fascio luminoso. **Questo prodotto contiene una sorgente luminosa di classe di efficienza energetica « F »**

SV : Om sladden är skadad måste den bytas ut av tillverkaren, dennes serviceavdelning eller en person med liknande kvalifikationer, för att undvika eventuella risker. LED-ljus. Titta inte in i ljustrålen. **Denna produkt innehåller en ljuskälla med energieffektivitetsklass « F »**

FI : Mikäli liitäntäjohdo tai kaapeliin eriste rikkoutuu on se vaihdettava valmistajalla, tämän huoltopisteessä, tai henkilöllä jolla on vastaava osaaminen. •LED-valo: Älä katso suoraan valonsäteeseen. **Tämä tuote sisältää valonlähteen, jonka energiatehokkuusluokka on « F »**

NO : Om ledningen er skadet, må den kun erstattes av produsent, produsentens serviceavdeling eller av personell med tilsvarende kompetanse for å unngå risiko. LED lampe. Ikke se rett inn i lyskilden. **Dette produktet inneholder en lyskilde i energieffektivitetsklasse « F »**

PL : Jeżeli zewnętrzny przewód elektryczny ulegnie uszkodzeniu, w związku z niebezpieczeństwem porażenia prądem jego wymiana może dokonać jedynie producent, jego przedstawiciel serwisowy lub inna wykwalifikowana osoba. Uwaga: oświetlenie LEDowe. Nie patrzeć prosto w światło. **Ten produkt zawiera źródło światła o klasie efektywności energetycznej « F »**