



UNILUX

BALY BAMBOO

BALY BAMBOO black



BALY BAMBOO white



BALY BAMBOO

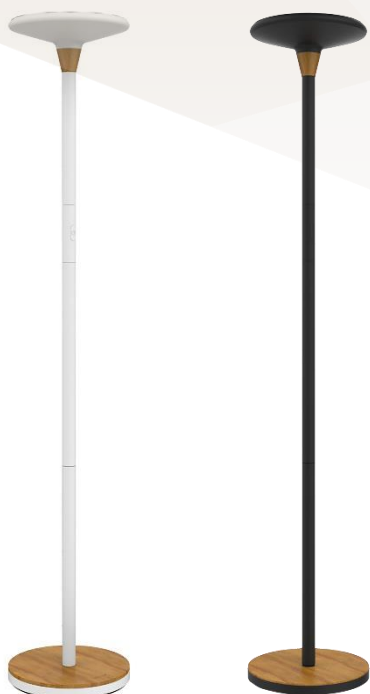

- **Easy to use:** its dimmer located on the mast makes it possible to find the most comfortable lighting for reading, writing and working.
- **Modern design:** designed in recyclable aluminum, its fine and clean lines allow this floor lamp to fit into both classic and modern decors.
- **Double effect:** direct lighting at 40% without glare for the worktop and indirect at 60% for the ambient light.
- **Equipped with quality LEDs (light-emitting diodes):** this street light emits a non-flickering and radiation-free light, helping to reduce eye strain. Low power consumption saves energy.
- **Stability:** the 8 mm thick sheet metal base allows good stability of the floor lamp.

Warranty: 2 years

Height: 180 cm

Head: Ø 34 cm

Base of the floor lamp in stable metal: 5 kg

Materials: steel with Epoxy paint finish and wood beech finish*



Professional replaceable light source (LED only)

Characteristics

Lux measurement upwards 55 cm from the light source:

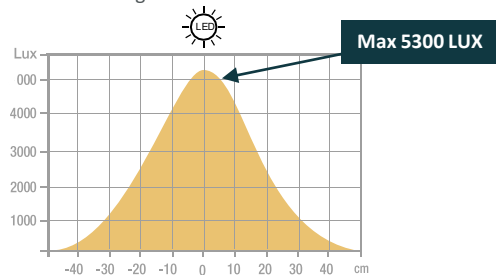

Measurement in nanometers of the light spectrum

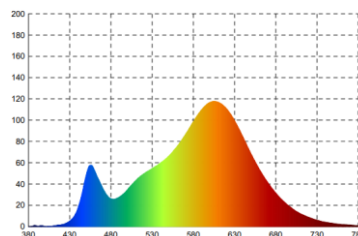

SAP. code	400153731	400140805
EAN code	3595560032075	3595560030378
Colors	White/Bamboo	Black/Bamboo
Luminous flow (Lm)	5 539 lm	5 539 lm
Lux at 55 cm (indirect)	5300	5300
Luminous Efficiency (Lm/W)	150	150
Color T*(K)	3000	3000
CRI	83	83
Source's lifetime (h)	40 000	40 000
Energy Consumption (kWh/1000h)	37	37
Net weight (kg)	8,12	8,12

OUR CSR COMMITMENTS

1. All our lighting are **100% repairable** thus limiting planned obsolescence.
2. Reduce our carbon footprint through our **ECO-DESIGN THINKING** approach.
3. Contribute to the preservation of the planet's natural resources by promoting the use of **recycled materials**.
4. Optimize our packaging to control our **transport costs**.
5. Highlight the **talent of our employees** by ensuring social equality.

Energy class

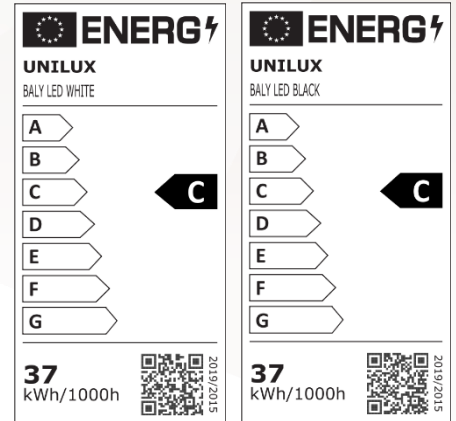

OUR EXPERTISE

1- Floor lamp with indirect lighting: An essential complementary light!

Because they're so easy to install and so decorative, indirect-lighting floor lamps are a firm favourite with the French! This floor lamp is ideal for illuminating a specific area of a room, or for adding a small, original decorative touch that will change the whole atmosphere of the room.

Thanks to its upward-directed light, which will reverberate off the ceiling, this floor lamp generally acts as a secondary or ambient light, providing you with high quality, high-performance lighting. It blends in perfectly with any room in your business:

- individual office
- open space
- meeting rooms
- high-traffic areas such as reception halls

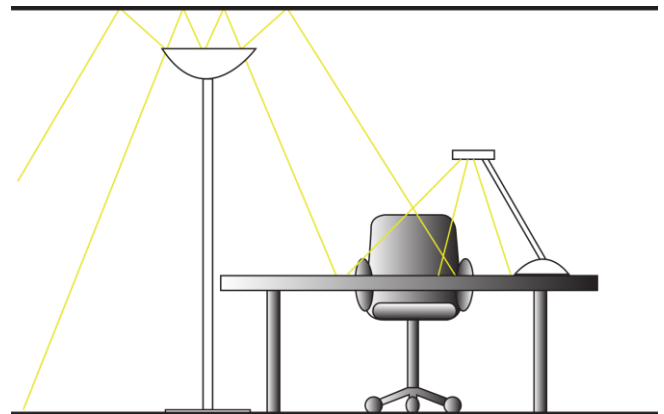

Lighting according to DIN EN 12464-1 * for the office

- **300 Lux:** deposit, copy, circulation areas
- **500 Lux:** writing, reading, data processing
- **500 Lux:** at the reception and at the counter
- **750 Lux:** technical drawing

OUR CERTIFICATIONS

Unilux is committed to an eco-responsible approach and ensures that its products respect this commitment. Indeed, we are very concerned about current environmental issues and we aspire to respond as best as possible to the concerns of our consumers on this subject. Sustainable development is at the heart of our strategy and we act for the environment. You will find below the different certifications that Unilux has and that prove its environmental commitment.





* DIN EN 12464-1 (DIN 5035-1): European standard which determines the lighting requirements for workstations in closed places, these satisfying the needs of comfort and visual performance. DIN EN 12464-1 replaced DIN 5035-1

USER GUIDE

 x1

 5 mins

 x1

 www.my-unilux.com

 (A) x1

 (B) x1

 (C) x1

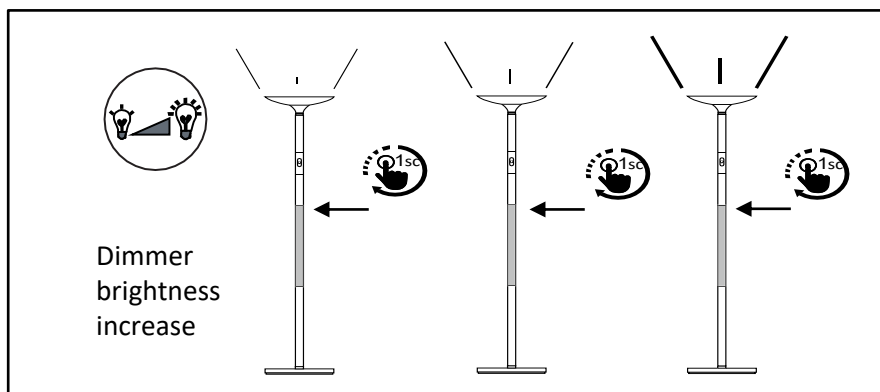
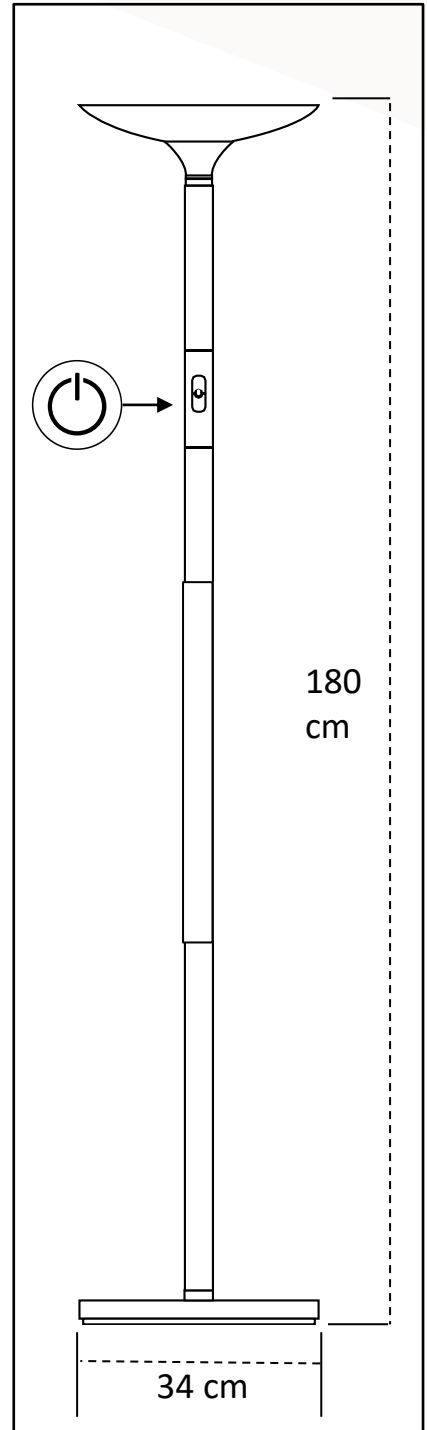
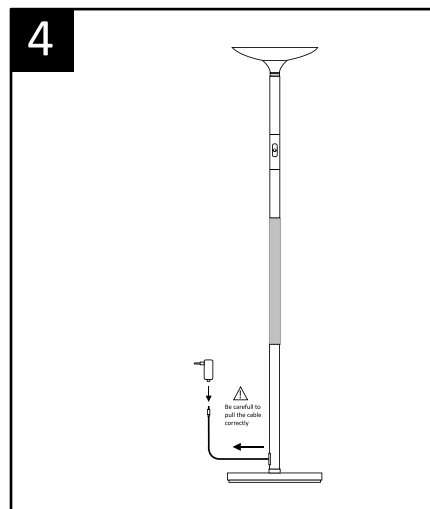
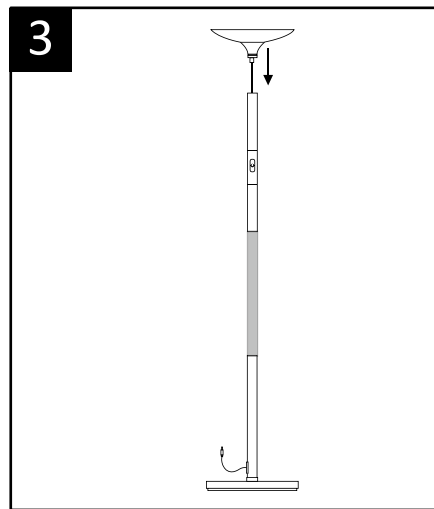
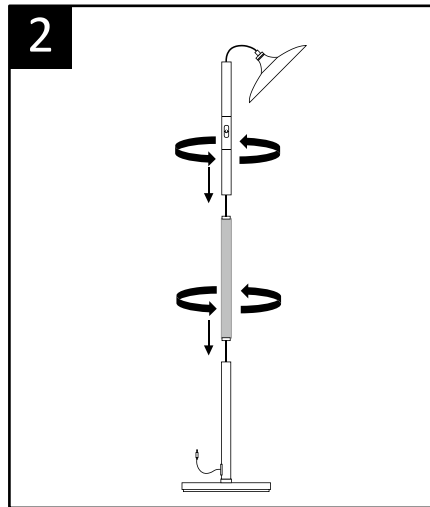
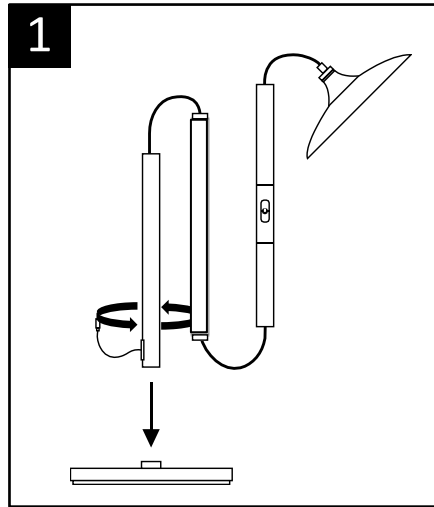
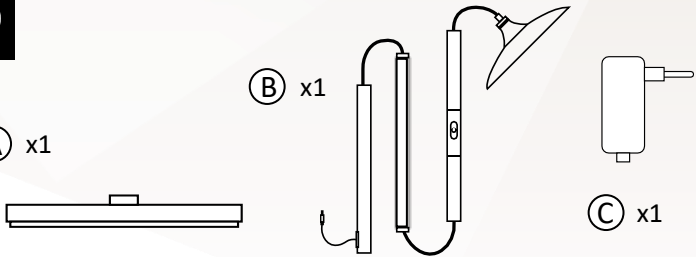

30 products available on pCon Planner

You will be able to obtain data on many UNILUX or OFML standard products and integrate them quickly and easily into 3D space layouts via pCon.



Download on our E-shop

Always available: photos in HD, data sheets, instruction manual, repairability instructions for all our products.



Do you have any questions?

Our after-sales service is always at your disposal

Tèl: +33 1 81 86 06 03

E-mail: contact.unilux@hamelinbrands.com

17 avenue du Parc TECHNOPOLIS

91380 Chilly Mazarin – France

Tèl: +33 1 81 86 06 00

www.my-unilyx.com

E-mail: contact.unilux@hamelinbrands.com

UNILUX