



UNILUX

---

CHOCOLATE

# CHOCOLATE



- **Comfort and well-being:** adapting to all body types, the daily use of this footrest will make you dynamic and productive at work while reducing fatigue and stress.
- **Ergonomic:** continuously adjustable in inclination from 0 to 25° and in height from 11 to 16.5 cm thanks to its screw pitch axis system that is carried out with the feet effortlessly.
- **Benefits:** promotes blood circulation, increases productivity and decreases absenteeism.
- **At work or at home:** this ergonomic footrest is the ideal accessory that will be your ally on a daily basis.
- **Anti-slip:** 4 rubber pads, non-slip prevents the footrest from slipping on all types of floors.

- Recommended by Occupational Medicine
- Inclination: 0° to 25°
- Dimensions: 42 cm x 32 cm
- Materials: polypropylene plastic structure / non-slip PVC pads



**Do not stand on it**

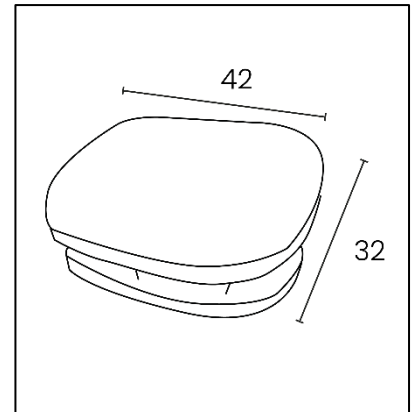
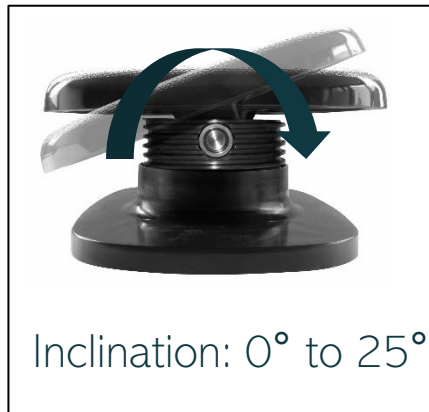

## Characteristics

SAP no.	100340816
Color	Black
Tilt	0° à 25°
Dimensions	42 cm x 32 cm
Head adjustment front	4 cm
Head adjustment rear	21 cm
Non-slip	Yes
Net weight	1,45 kg
Warranty	10 years
EAN code	3595560015931

# OUR CSR COMMITMENTS

1. All our lighting are **100% repairable** thus limiting planned obsolescence.
2. Reduce our carbon footprint through our **ECO-DESIGN THINKING** approach.
3. Contribute to the preservation of the planet's natural resources by promoting the use of **recycled materials**.
4. Optimize our packaging to control our **transport costs**.
5. Highlight the **talent of our employees** by ensuring social equality.

## OUR EXPERTISE

### Why use a footrest?

You have to clearly define your needs. This is why we advise you on the elements to take into account to choose the right ergonomic footrest. An ergonomic footrest is to be considered on the same level as ergonomic mice or ergonomic stools. The use of a footrest is really necessary. There are categories of footrests.

**1- footrests that have a fixed or adjustable tilting** will allow some people to compensate for the fact that they do not touch the ground and to avoid any inconvenience at ankle level. Their feet will be flat and the knees at the right 90° angle.

**2- the dynamic footrests** allowing a back and forth rocking movement of your feet will activate your calf muscles like a pump which will stimulate your blood circulation thus avoiding the tingling at the origin of the "heavy legs" effect . Finally, each of these movements will increase your muscle tone and reduce muscle tension.

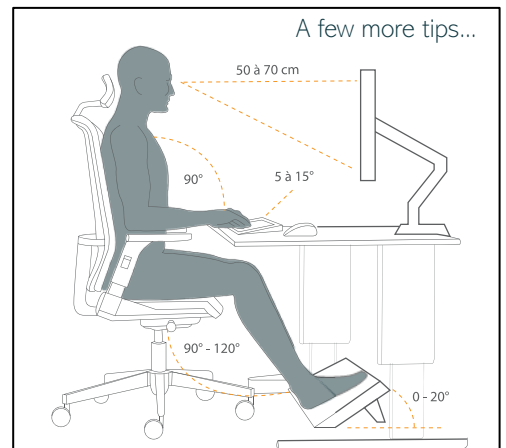
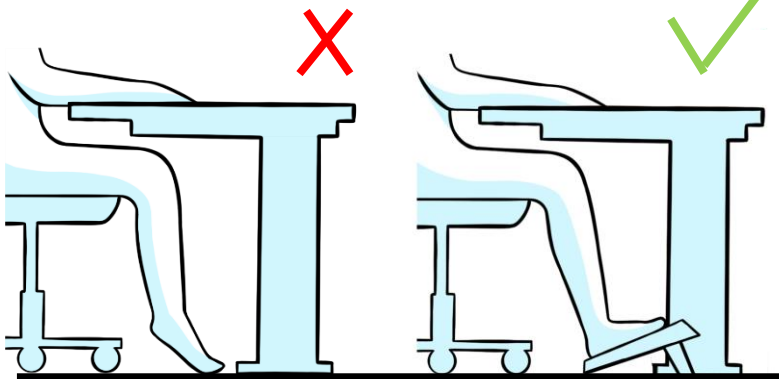

## OUR CERTIFICATIONS

Unilux is committed to an eco-responsible approach and ensures that its products respect this commitment. Indeed, we are very concerned about current environmental issues and we aspire to respond as best as possible to the concerns of our consumers on this subject. Sustainable development is at the heart of our strategy and we act for the environment. You will find below the different certifications that Unilux has and that prove its environmental commitment.



## 30 products available on pCon Planner

You will be able to obtain data on many UNILUX or OFML standard products and integrate them quickly and easily into 3D space layouts via pCon.



## Download on our E-shop

Always available: photos in HD, data sheets, instruction manual, repairability instructions for all our products.



## Do you have any questions?

Our after-sales service is always at your disposal

Tèl: +33 1 81 86 06 03

E-mail: [contact.unilux@hamelinbrands.com](mailto:contact.unilux@hamelinbrands.com)

17 avenue du Parc TECHNOPOLIS

91380 Chilly Mazarin – France

Tèl: +33 1 81 86 06 00

[www.my-unilyx.com](http://www.my-unilyx.com)

E-mail: [contact.unilux@hamelinbrands.com](mailto:contact.unilux@hamelinbrands.com)

UNILUX